

Housing:

d < 90: forged, heat-treated carbon steel

d ≥ 90: casting, heat-treated carbon steel

Bearings: mounted with GE..ES

Greasing:

fitted with hydraulic grease nipples

Sliding contact surface:

steel/steel, requiring maintenance

杆端体: d < 90: 碳钢, 精锻件; d ≥ 90: 碳钢, 精铸件

轴承: 装配 GE..ES 轴承

渗油: 带油嘴

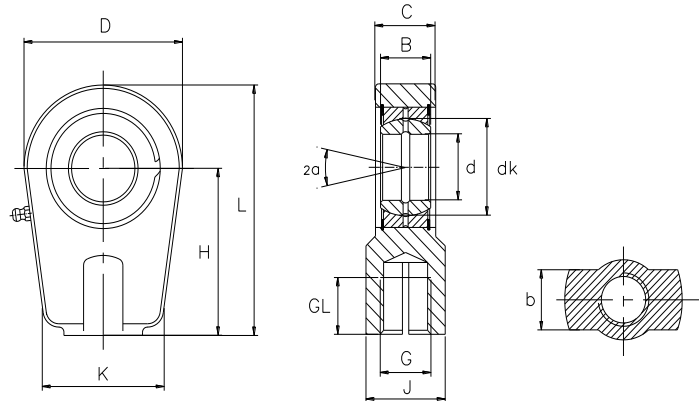

Bearing No.	Dimensions millimeters													Load ratings		Weight
型号	尺寸 mm													负荷		重量
	d	B	C	D	H	L	K	J	b	dk	G	GL	α	dyn.	stat.	
			max								6H	min		C (KN)	C ₀ (KN)	≈kg
SIRD 20 ES	20	16	19	56	50	80	46	25	17	29	M16x1.5	17	9	30	81	0.44
SIRD 25 ES	25	20	23	56	50	80	46	25	21	35.5	M16x1.5	17	7	48	72	0.47
SIRD 30 ES	30	22	28	64	60	94	50	32	26	40.7	M22x1.5	23	6	62	106	0.77
SIRD 35 ES	35	25	30	78	70	112	66	40	28	47	M28x1.5	29	6	80	153	1.24
SIRD 40 ES	40	28	35	94	85	135	76	49	33	53	M35x1.5	36	7	100	250	2.12
SIRD 50 ES	50	35	40	116	105	168	90	61	37	66	M45x1.5	46	6	156	365	3.74
SIRD 60 ES	60	44	50	130	130	200	120	75	46	80	M58x1.5	59	6	245	400	6.49
SIRD 70 ES	70	49	55	154	150	232	130	86	51	92	M65x1.5	66	6	315	540	9.88
SIRD 80 ES	80	55	60	176	170	265	160	105	55	105	M80x2	81	6	400	670	14.2
SIRD 90 ES	90	60	65	206	210	322	180	124	60	115	M100x2	101	5	490	980	20
SIRD 100 ES	100	70	70	231	235	360	200	138	65	130	M110x2	111	7	610	1,120	27.5
SIRD 110 ES	110	70	80	266	265	407	220	152	74	140	M120x3	125	6	655	1,700	45.6
SIRD 120 ES	120	85	90	340	310	490	257	172	84	160	M130x3	135	6	950	2,900	72

Female thread: for a left hand thread, add L (example: SILRD..)

内螺纹: 对左螺纹, 加 L (例如: SILRD..)