

Housing:

Forged weldable steel, with dowel pin on shanks

Bearings: mounted with GE..E(S)

Greasing:

$d \geq 15$: fitted with hydraulic grease nipples

Sliding contact surface:

steel/steel, requiring maintenance

杆端体: 可焊接的钢, 精锻件

轴承: 装配 GE..E(S) 轴承

渗油: $d \geq 15$: 带油嘴

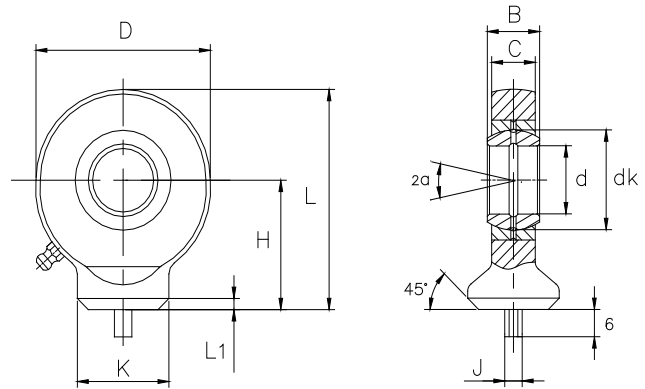

Bearing No.	Dimensions millimeters											Load ratings		Weight
型号	尺寸 mm											负荷		重量
	d	B	C	D	H	L	L1	K	J	dk	α	dyn.	stat.	
			max									C (KN)	C ₀ (KN)	≈kg
SK 10 E	10	9	7	29	24	38.5	2	15	3	16	12	8.15	15.6	0.041
SK 12 E	12	10	8	34	27	44	2	17.5	3	18	11	10.8	21.6	0.066
SK 15 ES	15	12	10	40	31	51	2.5	21	4	22	8	17	32	0.12
SK 17 ES	17	14	11	46	35	58	2.5	24	4	25	10	21.2	40	0.19
SK 20 ES	20	16	13	53	38	64.5	2.5	27.5	4	29	9	30	54	0.26
SK 25 ES	25	20	17	64	45	77	3	33.5	4	35.5	7	48	72	0.45
SK 30 ES	30	22	19	73	51	87.5	3	40	4	40.7	6	62	95	0.67
SK 35 ES	35	25	21	82	61	102	3	47	4	47	6	80	125	0.95
SK 40 ES	40	28	23	92	69	115	4	52	4	53	7	100	156	1.4
SK 45 ES	45	32	27	102	77	128	5	58	6	60	7	127	208	1.91
SK 50 ES	50	35	30	112	88	144	5	62	6	66	6	156	250	2.65
SK 60 ES	60	44	38	135	100	167.5	5	70	6	80	6	245	390	4.6
SK 70 ES	70	49	42	160	115	195	6	80	6	92	6	315	510	7
SK 80 ES	80	55	47	180	141	231	6	95	6	105	6	400	620	10.8