

**Housing:**

d < 70: forged, heat-treated carbon steel

d ≥ 70: casting, heat-treated carbon steel

**Bearings:** mounted with GEEW..ES

**Greasing:**

d ≥ 16: fitted with hydraulic grease nipples

**Sliding contact surface:**

steel/steel, requiring maintenance

杆端体: d < 70: 碳钢, 精锻件; d ≥ 70: 碳钢, 精铸件

轴承: 装配 GEEW..ES 轴承

渗油: d ≥ 16: 带油嘴

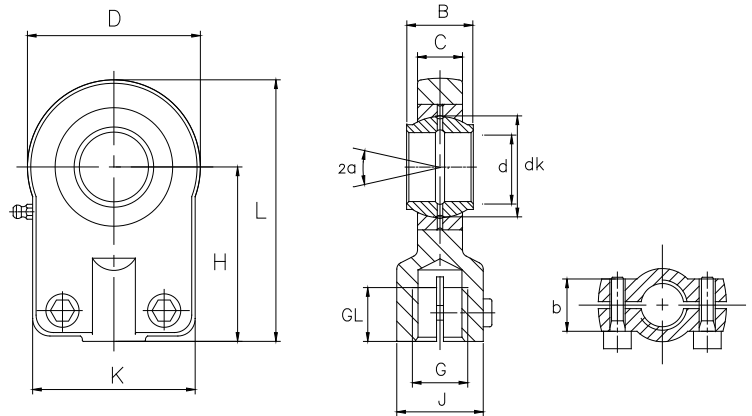

Bearing No.	Dimensions millimeters										Load ratings		Screw	Weight			
型号	尺寸 mm										负荷		锁紧螺钉	重量			
	d	B	C	D	H	L	K	J	b	dk	G	GL	α	dyn.	stat.		
			max								6H	min		C (KN)	C <sub>0</sub> (KN)		≈ kg
SIGEW 12 ES	12	12	11	32	38	54	32	16	15	18	M10×1.25	17	4	10.8	24.5	M5X16	0.1
SIGEW 16 ES	16	16	13	40	44	64	40	21	15	23	M14×1.5	19	4	17.6	36.5	M6X16	0.21
SIGEW 20 ES	20	20	17	47	52	77	47	25	19	29	M16×1.5	23	4	30	48	M8X20	0.35
SIGEW 25 ES	25	25	22	58	65	96	54	30	19	35.5	M20×1.5	29	4	48	78	M8X20	0.62
SIGEW 32 ES	32	32	28	71	80	118	66	38	22	43	M27×2	37	4	67	114	M10X25	1.17
SIGEW 40 ES	40	40	33	90	97	146	80	47	26	53	M33×2	46	4	100	204	M10X25	2.15
SIGEW 50 ES	50	50	41	109	120	179	96	58	32	66	M42×2	57	4	156	310	M12X35	4.4
SIGEW 63 ES	63	63	53	136	140	211	114	70	38	83	M48×2	64	4	255	430	M16X40	7.6
SIGEW 70 ES	70	70	57	155	160	245	135	80	42	92	M56×2	76	4	315	540	M16X40	10.1
SIGEW 80 ES	80	80	67	170	180	270	148	90	48	105	M64×3	86	4	400	695	M20X50	14.5
SIGEW 90 ES	90	90	72	185	195	296	160	100	52	115	M72×3	91	4	490	750	M20X55	17.5
SIGEW 100 ES	100	100	85	211	210	322	178	110	62	130	M80×3	96	4	610	1,060	M24X60	28
SIGEW 110 ES	110	110	88	235	235	364	190	125	62	140	M90×3	106	4	655	1,200	M24X60	32
SIGEW 125 ES	125	125	103	265	260	405	200	135	72	160	M100×3	113	4	950	1,430	M24X70	46.4
SIGEW 160 ES	160	160	130	326	310	488	250	165	82	200	M125×4	126	4	1,370	2,200	M24X80	81
SIGEW 200 ES	200	200	162	418	390	620	320	215	102	250	M160×4	161	4	2,120	3,650	M30X100	174

Female thread: for a left hand thread, add L (example: SILGEW..ES)

内螺纹: 对左螺纹, 加 L (例如: SILGEW..ES)