

Rod ends body:

Free-cutting carbon steel, Zinc plated

Insert:

Molded, maintenance free, reinforced Nylon

Inner ring:

Bearing steel, hardened, ground, polished, chrome plated

Sliding contact surface:

Steel/nylon, maintenance free

杆端体: 碳钢, 车制件, 镀白锌

镶嵌: 浇铸自润滑加强尼龙

内圈: 轴承钢, 淬火, 磨加工, 抛光, 镀硬铬

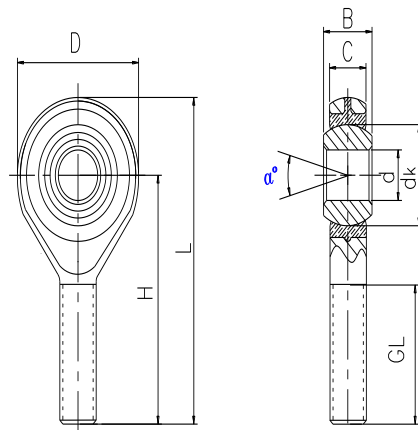

Bearing No.	Dimensions inches										Load	Weight
型号	尺寸 inch										负荷	重量
	d	B	C	D	H	L	dk	G	GL	α	stat.	
	+0.020 -0.000	± 0.005		± 0.015	± 0.060			Thread UNF-3A	± 0.062		C. (Lbf)	\approx Lbs
SAZ 3N	.1900	.312	.250	.625	1.250	1.5625	.437	10-32	.750	13	1,210	.023
SAZ 4N	.2500	.375	.281	.750	1.562	1.937	.500	1/4-28	1.000	16	2,470	.040
SAZ 5N	.3125	.437	.344	.875	1.875	2.3125	.625	5/16-24	1.250	14	2,740	.071
SAZ 6N	.3750	.500	.406	1.000	1.938	2.438	.719	3/8-24	1.250	12	4,210	.107
SAZ 7N	.4375	.562	.437	1.125	2.125	2.6875	.812	7/16-20	1.375	14	5,350	.148
SAZ 8N	.5000	.625	.500	1.312	2.438	3.094	.937	1/2-20	1.500	12	6,430	.232
SAZ 10N	.6250	.750	.562	1.500	2.625	3.375	1.125	5/8-18	1.625	16	8,300	.364
SAZ 12N	.7500	.875	.687	1.750	2.875	3.75	1.312	3/4-16	1.750	14	10,900	.568

Bearing No.	Dimensions millimeters										Load	Weight
型号	尺寸 mm										负荷	重量
	d	B	C	D	H	L	dk	G	GL	α	stat.	
	+0.05 -0.00	± 1.3		± 3.8	± 1.52			Thread UNF-3A	± 1.57		C. (KN)	\approx kgs
SAZ 3N	4.826	7.92	6.35	15.88	31.75	39.69	11.10	10-32	19.05	13	5.4	.010
SAZ 4N	6.350	9.53	7.14	19.05	39.67	49.20	12.70	1/4-28	25.40	16	11.0	.018
SAZ 5N	7.938	11.10	8.74	22.23	47.63	58.75	15.88	5/16-24	31.75	14	12.2	.032
SAZ 6N	9.525	12.70	10.31	25.40	49.23	61.93	18.26	3/8-24	31.75	12	18.7	.048
SAZ 7N	11.113	14.27	11.10	28.58	53.98	68.27	20.62	7/16-20	34.93	14	23.8	.067
SAZ 8N	12.700	15.88	12.70	33.32	61.93	78.59	23.80	1/2-20	38.10	12	28.6	.105
SAZ 10N	15.875	19.05	14.27	38.10	66.68	85.73	28.58	5/8-18	41.28	16	36.9	.165
SAZ 12N	19.050	22.23	17.45	44.45	73.03	95.26	33.32	3/4-16	44.45	14	48.5	.258

Male thread: for a left hand thread, add L (example: SAZL..N)

外螺纹: 对左螺纹, 加 L (例如: SAZL..N)

