

Housing:

Free-cutting or forged carbon steel, Zinc plated, liner with PTFE

Inner ring:

Bearing steel, hardened, ground, polished, chrome plated

Sliding contact surface:

Steel/PTFE, maintenance free

杆端体: 碳钢, 车制件或精锻件, 镀白锌, 衬有PTFE自润滑材料

内圈: 轴承钢, 淬火, 磨加工, 抛光, 镀铬

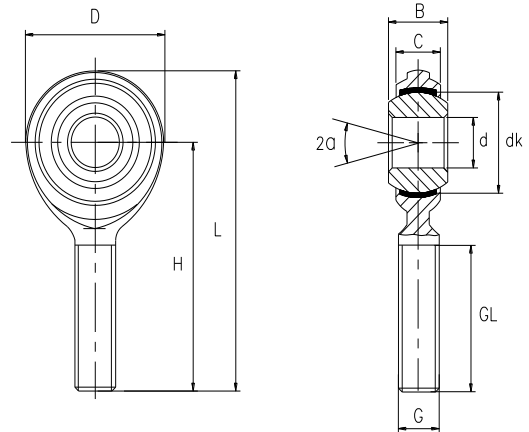

Bearing No.	Dimensions inches										Load	Weight
型号	尺寸 inch										负荷	重量
	d	B	C	D	H	L	dk	G	GL	α	stat.	
	+0.015	+0.000			± 0.015			Thread	+0.062		C. (Lbf)	\approx Lbs
	-0.0005	-0.005					UNF-3A	-0.031				
GAZ 3T	.1900	.312	.234	.625	1.250	1.5625	.437	10-32	.750	20	902	.03
GAZ 4T	.2500	.375	.250	.750	1.562	1.937	.500	1/4-28	1.000	27	1,810	.04
GAZ 5T	.3125	.437	.312	.875	1.875	2.3125	.593	5/16-24	1.250	22	2,980	.07
GAZ 6T	.3750	.500	.359	1.000	1.938	2.438	.687	3/8-24	1.250	22	4,250	.11
GAZ 7T	.4375	.562	.406	1.125	2.125	2.6875	.781	7/16-20	1.375	21	5,310	.15
GAZ 8T	.5000	.625	.453	1.312	2.438	3.094	.875	1/2-20	1.500	20	7,210	.24
GAZ 10T	.6250	.750	.484	1.500	2.625	3.375	1.062	5/8-18	1.625	26	8,210	.36
GAZ 12T	.7500	.875	.593	1.750	2.875	3.75	1.250	3/4-16	1.750	24	12,280	.57

Bearing No.	Dimensions millimeters										Load	Weight
型号	尺寸 mm										负荷	重量
	d	B	C	D	H	L	dk	G	GL	α	stat.	
	+0.038	+0.00			± 0.38			Thread	+1.57		C. (KN)	\approx kgs
	-0.013	-0.13					UNF-3A	-0.79				
GAZ 3T	4.826	7.92	5.94	15.88	31.75	39.69	11.10	10-32	19.05	20	4	.014
GAZ 4T	6.350	9.53	6.35	19.05	39.67	49.195	12.70	1/4-28	25.4	27	8	.018
GAZ 5T	7.938	11.10	7.92	22.23	47.63	58.745	15.06	5/16-24	31.75	22	13.2	.032
GAZ 6T	9.525	12.70	9.12	25.40	49.23	61.93	17.45	3/8-24	31.75	22	18.9	.050
GAZ 7T	11.113	14.27	10.31	28.58	53.98	68.27	19.84	7/16-20	34.93	21	23.6	.068
GAZ 8T	12.700	15.88	11.50	33.32	61.93	78.59	22.23	1/2-20	38.1	20	32	.109
GAZ 10T	15.875	19.05	12.29	38.10	66.68	85.73	26.97	5/8-18	41.28	26	36.5	.163
GAZ 12T	19.050	22.23	15.06	44.45	73.03	95.255	31.75	3/4-16	44.45	24	54.6	.259

Male thread: for a left hand thread, add L (example: GAZL..T)

外螺纹:对左螺纹, 加 L (例如: GAZL..T)

